

INFORMATION DISCLOSURE STATEMENT BY APPLICANT (Not for submission under 37 CFR 1.99)	Application Number		
	Filing Date		
	First Named Inventor	NICHOL NELSON	
	Art Unit		
	Examiner Name		
	Attorney Docket Number	4800-PA1	

U.S.PATENTS						
Examiner Initial*	Cite No	Patent Number	Kind Code ¹	Issue Date	Name of Patentee or Applicant of cited Document	Pages,Columns,Lines where Relevant Passages or Relevant Figures Appear
	1	1595395		1926-08-10	HERBENER	
	2	2529628		1950-11-14	POLLOCK	
	3	2688303		1954-09-07	LEANDER	
	4	2888900		1959-06-02	SCARLET	
	5	3043732		1962-07-10	SHEPHERD, JR.	
	6	3620881		1971-11-16	HERBERT	
	7	3632291		1972-01-04	DEFAGO, ET AL.	
	8	3766854		1973-10-23	SCARLET	

**INFORMATION DISCLOSURE
STATEMENT BY APPLICANT**
(Not for submission under 37 CFR 1.99)

Application Number		
Filing Date		
First Named Inventor	NICHOL NELSON	
Art Unit		
Examiner Name		
Attorney Docket Number	4800-PA1	

	9	3788269		1974-01-29	SCARLET	
	10	4471873		2008-09-19	THOMAS	
	11	4813369		1989-03-21	MORELAND	
	12	5244715		1993-09-14	KUCHER	
	13	5517941		1996-05-21	FISHER	
	14	5975087		1999-11-02	JANG	
	15	6155197		2000-12-05	STANLEY	
	16	6598558		2003-07-29	GRIFFIN	
	17	6857801		2005-02-22	VAN BEVER	
	18	6866002		2005-03-15	CHRISTY, ET AL.	
	19	7100528		2006-09-05	BOTTOM	

**INFORMATION DISCLOSURE
STATEMENT BY APPLICANT**
(Not for submission under 37 CFR 1.99)

Application Number		
Filing Date		
First Named Inventor	NICHOL NELSON	
Art Unit		
Examiner Name		
Attorney Docket Number	4800-PA1	

	20	D505885		2005-06-07	PUETT, III	
	21	7125597		2006-10-24		

If you wish to add additional U.S. Patent citation information please click the Add button.

U.S.PATENT APPLICATION PUBLICATIONS

Examiner Initial*	Cite No	Publication Number	Kind Code ¹	Publication Date	Name of Patentee or Applicant of cited Document	Pages, Columns, Lines where Relevant Passages or Relevant Figures Appear
	1	20030200683		2003-10-30	GAILEN	
	2	20030217685		2003-11-27	ALDRIGE	
	3	20050204599		2005-09-22	MYLES	
	4	20060183101		2008-09-19	WILLIAMS, ET AL.	
	5	20060249069		2006-11-09	McCANN	

If you wish to add additional U.S. Published Application citation information please click the Add button.

FOREIGN PATENT DOCUMENTS

Examiner Initial*	Cite No	Foreign Document Number ³	Country Code ² i	Kind Code ⁴	Publication Date	Name of Patentee or Applicant of cited Document	Pages, Columns, Lines where Relevant Passages or Relevant Figures Appear	T ⁵
-------------------	---------	--------------------------------------	-----------------------------	------------------------	------------------	---	--	----------------

INFORMATION DISCLOSURE STATEMENT BY APPLICANT (Not for submission under 37 CFR 1.99)	Application Number		
	Filing Date		
	First Named Inventor	NICHOL NELSON	
	Art Unit		
	Examiner Name		
	Attorney Docket Number	4800-PA1	

	1								<input type="checkbox"/>
--	---	--	--	--	--	--	--	--	--------------------------

If you wish to add additional Foreign Patent Document citation information please click the Add button

NON-PATENT LITERATURE DOCUMENTS

Examiner Initials*	Cite No	Include name of the author (in CAPITAL LETTERS), title of the article (when appropriate), title of the item (book, magazine, journal, serial, symposium, catalog, etc), date, pages(s), volume-issue number(s), publisher, city and/or country where published.	T ⁵
	1	Friends Banner - http://www.michaels.com/art/online/projectsheet?pid=k00521 , Copyright 1999-2008	<input type="checkbox"/>
	2	Print A Flag web site - www.PrintAFlag.com , Copyright 2006.	<input type="checkbox"/>

If you wish to add additional non-patent literature document citation information please click the Add button

EXAMINER SIGNATURE

Examiner Signature		Date Considered	
--------------------	--	-----------------	--

*EXAMINER: Initial if reference considered, whether or not citation is in conformance with MPEP 609. Draw line through a citation if not in conformance and not considered. Include copy of this form with next communication to applicant.

¹ See Kind Codes of USPTO Patent Documents at www.USPTO.GOV or MPEP 901.04. ² Enter office that issued the document, by the two-letter code (WIPO Standard ST.3). ³ For Japanese patent documents, the indication of the year of the reign of the Emperor must precede the serial number of the patent document. ⁴ Kind of document by the appropriate symbols as indicated on the document under WIPO Standard ST.16 if possible. ⁵ Applicant is to place a check mark here if English language translation is attached.

2

3

4

Field of the Invention

5

6 The present invention relates to flags and to methods
7 of making flags.

8

9

10

Background of the Invention

11

12 A traditional flag is a piece of cloth flown from a
13 pole or mast, generally used for signaling or
14 identification. The first flags were used to assist
15 military coordination on battlefields, and flags have since
16 evolved into a general tool for rudimentary signaling and
17 identification. National flags are patriotic symbols with
18 varied wide-ranging interpretations, often including strong
19 military associations due to their original and ongoing
20 military uses. Other forms of flags include flags at sea,
21 religious flags, linguistic flags, sports flags, railway
22 flags, and flags in politics.

23

1 Flags are highly visible and, thus, excellent for
2 communicating messages and information. As such, flags are
3 often used in messaging, advertising, and also for
4 decorative purposes. Flags are difficult and time-
5 consuming to make. As such, specialty flags containing
6 specific messaging, advertising, decoration, or other
7 selected indicia, must often be ordered from specialty
8 flag-making companies or organizations, often at
9 significant cost and delay. Given the increased
10 utilization of flags for personal use and use in
11 advertising goods and services, political affiliations, and
12 other messages, it is evident that improvements in the
13 field of flags and flag making are needed.

14

1 the flag to the flagpole. The step of adhering the backing
2 to the second face of the flag blank further includes
3 adhesively adhering the backing to the second face of the
4 flag blank. The step of applying the flag design indicia
5 to the first face of the flag blank converting the flag
6 blank to a flag preferably includes imprinting the flag
7 design indicia onto the first face of the flag blank. The
8 step of imprinting the flag design indicia onto the first
9 face of the flag blank includes, in a preferred embodiment,
10 providing a personal computer operatively coupled to a
11 printer, designing the flag design indicia with the
12 personal computer, placing the flag blank in the printer,
13 activating the printer with the personal computer to run
14 the flag blank through the printer imprinting the flag
15 design indicia onto the first face of the flag blank, and
16 the backing applied to the second face of the flag blank
17 supporting the flag blank as the flag blank is run through
18 the printer imprinting the flag design indicia onto the
19 first face of the flag blank. The step of removing the
20 backing from the second face of the flag further includes
21 peeling the backing away from the second face of the flag.
22 A preferred method of mounting the flag to the flagpole
23 includes steps of providing a flag support, mounting the
24 flag support to the flagpole, and adhering the flag to the

1 flag support. If desired, the flag can be adhered to the
2 flag support before mounting the flag support to the
3 flagpole. The step of adhering the flag to the flag
4 support further includes adhesively adhering the flag to
5 the flag support.

6

7 A method of making a flag according to the principle
8 of the invention includes providing a flag-making kit
9 including a flag blank having opposed first and second
10 faces and a backing adhered to the second face of the
11 backing, a flagpole, a flag support adapted to secure a
12 flag to the flagpole, a package, the flag blank, and flag
13 support enclosed in the package, and the package attached
14 to the flagpole and together having the appearance of a
15 flag raised by the flagpole. The method next specifies
16 detaching the package from the flagpole, removing the flag
17 blank and the flag support from the package, applying flag
18 design indicia to the first face of the flag blank
19 converting the flag blank to a flag, the backing applied to
20 the second face of the flag blank supporting the flag blank
21 during the step of applying the flag design indicia to the
22 first face of the flag blank converting the flag blank to
23 the flag, removing the backing from the second face of the
24 flag, attaching the flag to the flag support, and mounting

1 the flag support to the flagpole. The step of applying the
2 flag design indicia to the first face of the flag blank
3 converting the flag blank to a flag further includes
4 imprinting the flag design indicia onto the first face of
5 the flag blank. The step of imprinting the flag design
6 indicia onto the first face of the flag blank preferably
7 includes providing a personal computer operatively coupled
8 to a printer, designing the flag design indicia with the
9 personal computer, placing the flag blank in the printer,
10 activating the printer with the personal computer to run
11 the flag blank through the printer imprinting the flag
12 design indicia onto the first face of the flag blank, and
13 the backing applied to the second face of the flag blank
14 supporting the flag blank as the flag blank is run through
15 the printer imprinting the flag design indicia onto the
16 first face of the flag blank. The step of removing the
17 backing from the second face of the flag includes peeling
18 the backing away from the second face of the flag. The
19 step of attaching the flag to the flag support further
20 includes adhering the flag to the flag support. A
21 preferred step of adhering the flag to the flag support
22 includes adhesively adhering the flag to the flag support.
23

1 A method of making a flag according to the principle
2 of the invention includes providing a flag blank having
3 opposed first and second faces and a backing adhered to the
4 second face of the flag blank, providing a personal
5 computer operatively coupled to a printer, designing flag
6 design indicia with the personal computer, placing the flag
7 blank in the printer, activating the printer with the
8 personal computer to run the flag blank through the printer
9 imprinting the flag design indicia onto the first face of
10 the flag blank converting the flag blank to a flag, the
11 backing applied to the second face of the flag blank
12 supporting the flag blank as the flag blank is run through
13 the printer imprinting the flag design indicia onto the
14 first face of the flag blank converting the flag blank to
15 the flag, removing the backing from the second face of the
16 flag, providing a flagpole, and mounting the flag to the
17 flagpole. The step of removing the backing from the second
18 face of the flag further includes peeling the backing away
19 from the second face of the flag. The step of mounting the
20 flag to the flagpole further includes providing a flag
21 support, attaching the flag to the flag support, and
22 attaching the flag support to the flagpole. In accordance
23 with a preferred embodiment, the step of attaching the flag

1 to the flag support further includes adhesively adhering
2 the flag to the flag support.

3

4 A method of making a flag according to the principle
5 of the invention includes providing a flag blank having a
6 pliancy, applying reinforcement to the flag blank reducing
7 the pliancy of the flag blank, providing a personal
8 computer operatively coupled to a printer, designing flag
9 design indicia with the personal computer, placing the flag
10 blank in the printer, activating the printer with the
11 personal computer to run the flag blank through the printer
12 imprinting the flag design indicia onto the flag blank
13 converting the flag blank to a flag, removing the
14 reinforcement from the flag blank, providing a flagpole,
15 and mounting the flag to the flagpole. The step of
16 mounting the flag to the flagpole further includes
17 providing a flag support, attaching the flag to the flag
18 support, and attaching the flag support to the flagpole.
19 In accordance with a preferred embodiment, the step of
20 attaching the flag to the flag support further includes
21 adhesively adhering the flag to the flag support.

22

1 BRIEF DESCRIPTION OF THE DRAWINGS

2
3 Referring to the drawings:

4
5 FIG. 1 is a perspective view of a flag-making kit
6 constructed and arranged in accordance with the principle
7 of the invention, the flag-making kit including flag-making
8 materials housed in a package attached to a flagpole;

9
10 FIG. 2 is a front plan view of the flag-making kit of
11 FIG. 1;

12
13 FIG. 3 is a fragmented perspective view of the flag-
14 making kit of FIG. 1 illustrating the package as it would
15 appear being detached from the flag pole and opened to
16 remove the flag-making materials from the package;

17
18 FIGS. 4A-4C illustrate a flag blank, an instruction
19 sheet, and an advertising cover art sheet, respectively,
20 each forming a part of the flag-making materials of the
21 flag-making kit of FIG. 1;

22

1 FIG. 5 is a perspective view of a flag support forming
2 a part of the flag-making materials of the flag-making kit
3 of FIG. 1, the flag support to attach a flag to the
4 flagpole of the flag-making kit of FIG. 1;

5

6 FIG. 6 is a perspective view of the flag blank of FIG.
7 4A;

8

9 FIG. 7 is a sectional view taken along line 7-7 of
10 FIG. 6; and

11

12 FIG. 8 is an enlarged top plan view of the instruction
13 sheet illustrated in FIG. 4B marked with indicia forming a
14 test flag template;

15

16 FIG. 9 is an enlarged bottom plan view of the
17 instruction sheet illustrated in FIG. 4B marked with
18 indicia forming instructions for making a flag;

19

20 FIG. 10 is a perspective of a workstation including a
21 personal computer and a printer used to design and imprint
22 flag design indicia onto the flag blank illustrated in FIG.
23 4A to convert the flag blank in to a flag;

24

1 FIG. 11 is a perspective of the flag blank of FIG. 4A
2 shown as it would appear having imprinted thereon flag
3 design indicia converting the flag blank into a flag, and
4 the flag shown as it would appear being peeled away from an
5 applied reinforcement;

6
7 FIG. 12 is a perspective view of the flag of FIG. 11,
8 the flag support of FIG. 5, and the flagpole of the flag-
9 making kit of FIG. 1 shown prior to assembly to form a
10 completed flag;

11
12 FIG. 13 is an enlarged perspective view of the flag,
13 flag support, and flagpole of FIG. 12 shown assembled to
14 form a completed flag;

15
16 FIG. 14 is a sectional view taken along line 14-14 of
17 FIG. 13;

18
19 FIG. 15 is a view very similar to that of FIG. 13
20 illustrating abutments formed on the flagpole on either
21 side of a flag support of a flag constructed and arranged
22 in accordance with the principle of the invention; and

23

1 FIG. 16 is a perspective view of a point-of-purchase
2 display displaying flag-making kits constructed and
3 arranged in accordance with the principle of the invention.
4

1 DETAILED DESCRIPTION OF PREFERRED EMBODIMENTS

2
3 A flag-making kit and associated methods of making
4 flags and flags formed therewith are disclosed.

5
6 Turning now to the drawings, in which like reference
7 characters indicate corresponding elements throughout the
8 several views, attention is first directed to FIGS. 1 and
9 2, in which there is illustrated a flag-making kit 20
10 constructed and arranged in accordance with the principle
11 of the invention including flag-making materials packaged
12 and housed in a package 21 attached to a flagpole 22.
13 Package 21 is formed of clear, transparent film material,
14 such as clear acetate film, clear polyester Mylar® film, or
15 the like, which serves not only to contain the flag-making
16 materials, which are described later in this specification,
17 but also allows them to be seen through package 21. In
18 other embodiments, the material used to form package 21 can
19 be opaque. Package 21, together with its contents, namely,
20 the flag-making materials, is broad and flat and, in this
21 particular example, is generally rectangular in shape as
22 illustrated and includes opposed, parallel inner and outer
23 edges 25 and 26, and opposed, parallel upper and lower
24 edges 27 and 28.

1 Flagpole 22 is formed of wood, plastic, aluminum, or
2 other substantially rigid material or combination of
3 materials, and is an elongate member and used to support a
4 flag. In this preferred embodiment, flagpole 22 is a dowel
5 or rod 30 having opposed upper and lower ends 31 and 32,
6 and a length extending therebetween of approximately 2-5
7 feet, although the length of rod 30 can be of any suitable
8 or desired length and can be a length outside the disclosed
9 range without departing from the invention. In this
10 embodiment, upper end 31 of flagpole 22 is formed with a
11 decorative tip 33. Inner edge 25 of package 21 is secured
12 to flagpole 22. Inner edge 25 of package 21 extends
13 downwardly along a length of flagpole 22 from upper edge 27
14 of package 21 just below and adjacent to decorative tip 33
15 formed in upper end 31 to lower edge 28 of package 21. In
16 this embodiment, inner edge 25 extends along approximately
17 one-third of the overall length of flagpole 22 from upper
18 edge 27 of package 21 at upper end 31 of flagpole 22 to
19 lower edge 28 of package 21 located between upper end 31 of
20 flagpole 22 and lower end 32 of flagpole 22, and this can
21 be varied depending on the length of flagpole 22 and the
22 width of package 21. Package 21, together with the flag-
23 making materials therein contained, extends outwardly from
24 inner edge 25 secured to flagpole 22 to outer edge 26

1 having the appearance of a flag raised by flagpole 22 as
2 clearly illustrated in FIGS. 1 and 2.

3

4 In the present embodiment, inner edge 25 of package 21
5 is formed with a flap 40 that encircles flagpole 22 and is
6 folded back onto the underside of package 21 and secured to
7 the underside of package 21 with adhesive, heat bonding, or
8 the like, securing inner edge 25 of package 21 to flagpole
9 22. Flap 40 encircles and embraces flagpole 22 tightly
10 forming a firm attachment of package 21 to flagpole 22. If
11 desired, an adhesive can be applied between flap 40 and
12 flagpole 22 to help secure package 21 to flagpole 22.
13 Alternatively, one or more staples, pins, clips, or other
14 like or similar fastener form can be used to secure flap 40
15 to flagpole 22 and, moreover, package 21 to flagpole 22.

16

17 The formed flag-making kit 20 illustrated in FIGS. 1
18 and 2 occupies little space and is thus easily packaged in
19 bulk and shipped, and may be easily and conveniently
20 displayed at point-of-purchase displays at retail outlets.
21 FIG. 16 is generally representative of a point-of-purchase
22 display 55 consisting of a supporting base 56 receiving and
23 maintaining flag-making kits 20 in an upright position.
24 Because flag-making kit 20 has the appearance of a flag

1 raised by flagpole 22, which is illustrated in FIG. 16, the
2 appearance of flag-making kit 20 as provided by the
3 structure of flag-making kit 20 as herein described evokes
4 immediate consumer interest in flag-making kit 20, and
5 functions to promote impulse purchasing of flag-making kit
6 20, in accordance with the principle of the invention.

7

8 Flag-making kit 20 is used to make a flag according to
9 exemplary flag-making methods according to the principle of
10 the invention. To make a flag according to the principle
11 of the invention, the flag-making materials of package 21
12 are removed from package 21 and package 21 is, in turn,
13 removed from flagpole 22 and discarded. Because package 21
14 is made of a selected clear plastic material as described
15 above, package 21 is recyclable, and rather than simply
16 being thrown away may more preferably be deposited for
17 recycling.

18

19 To remove the flag-making materials from package 21
20 and to remove or otherwise detach package 21 from flagpole
21 22, flap 40 is taken up, such as by hand, and torn or
22 otherwise peeled away from the underside of package 21 as
23 illustrated in FIG. 3 exposing an opening 41 into an
24 interior volume 42 of package 21 within which flag-making

1 materials 43 are maintained. Once package 21 is so opened,
2 flag-making materials 43 are removed from volume 42 through
3 opening 41, and package 21 is simply pulled away from
4 flagpole 22 and discarded, preferably for recycling. In
5 packaging flag-making materials 43 in package 21, package
6 21 is provided in an open form, flag-making materials 43
7 are applied into interior volume 42 through opening 41,
8 flap 40 is applied to flagpole 22, is wrapped about
9 flagpole 22 to encircle flagpole 22, and then flap 40 is
10 bonded to the underside of package 21, such as with
11 adhesive, heat bonding, or the like. As a matter of
12 illustration and reference in conjunction with a preferred
13 embodiment, in FIG. 3 an adhesive denoted at 44 is shown
14 applied to an inner side of flap 40 in the form of a strip
15 that secures flap 40 to the underside of package 21, the
16 bond of which is overcome by taking up flap 40 by hand and
17 applying a force to flap 40 peeling flap 40 away from the
18 underside of package 21 to open opening 41 into volume 42
19 of package 21 in the removal of flag-making materials 43
20 from volume 42 of package 21 through opening 41.

21

22 Flag-making materials denoted generally at 43 in FIG.
23 3 are illustrated in FIGS. 4A-4C, and FIG. 5, the details
24 of which are now addressed in turn. Referencing FIGS. 4A-

1 4C, and FIG. 5, flag-making materials 43 include a flag
2 blank 50 illustrated in FIG. 4A, an instruction sheet 51
3 illustrated in FIG. 4B, an advertisement sheet 52
4 illustrated in FIG. 4C, and a flag support 53 illustrated
5 in FIG. 5.

6

7 Flag blank 50 illustrated in FIGS. 4A, 6, and 7,
8 consists of a broad, flat sheet material. The material
9 forming flag blank 50 can consist of cellulosic material,
10 flashspun high-density polyethylene material commonly found
11 under the brand name Tyvek®, woven, non-woven, knitted, or
12 felted cloth or cloth-like material or fabric or fabric-
13 like material made of cotton, polyester, spandex, a
14 combination of two or more of the named materials or other
15 similar material or combination of materials, and has
16 opposed first and second faces 60 and 61. In this
17 embodiment, flag blank 50 is generally rectangular in shape
18 having opposed parallel inner and outer edges 62 and 63,
19 and opposed upper and lower edges 64 and 65 together
20 forming the perimeter of flag blank 50.

21

22 Flag blank 50 has a pliancy. The pliancy of flag
23 blank 50 is provided by the material or combination of
24 materials used for form flag blank 50 as disclosed above.

1 According to the principle of the invention in the present
2 embodiment, reinforcement is applied to flag blank 50 to
3 reduce the pliancy of flag blank 50 in preparation for use
4 of flag blank 50 in a flag-making method according to the
5 principle of the invention. FIG. 7 is a sectional view of
6 flag blank 50 taken along line 7-7 of FIG. 6. In FIG. 6,
7 the reinforcement applied to flag blank 50 in a preferred
8 embodiment a backing 66, which is thin sheet of material
9 fashioned of paper, latex, synthetic elastomer, or other
10 like or similar material or combination of materials.
11 Backing 66 is coextensive relative to second face 61 of
12 flag blank 50 and thus, like flag blank 50, generally
13 rectangular in shape. In constructing flag blank 50 to
14 form a component of flag-making kit 20, backing 66 is
15 applied and adhered to second face 61 of flag blank 50
16 covering second face 61 of flag blank 50. Backing 66 is
17 pliant, but is less pliant than flag blank 50. As such, so
18 applied to flag blank 50 as described above, backing 66, in
19 accordance with the principle of the invention, reinforces
20 flag blank 50 and as such supports or otherwise provides
21 support for flag blank 50. Because backing 66 is less
22 pliant than flag support 50, backing 66 applied to flag
23 blank 50 imparts a pliancy to flag blank 50 that is less
24 than the pliancy of blank 50 without backing 66 attached

1 thereto as described above. In sum, flag blank 50 has a
2 pliancy greater than the pliancy of backing 66 applied to
3 second face 61 of flag blank 50, which causes backing 66
4 reduce the pliancy of flag blank 50 to reinforce and
5 provide support for flag blank 50 during the process of
6 imprinting flag design indicia onto flag blank 50, and,
7 more particularly, allowing flag blank 50 to be run through
8 a printer in the making of a flag, the details of which are
9 discussed below.

10

11 In this embodiment, an adhesive 67 is applied between
12 backing 66 and second face 61 of flag blank 50 adhesively
13 adhering backing 66 to second face 61 of flag blank 50.
14 Adhesive 67 is a low-tack adhesive applied to backing 66
15 which, when brought into contact with second face 61 of
16 flag blank 50 adheres backing 66 to second face 61 of flag
17 blank 50. Adhesive 67 is applied to backing 66, such as in
18 the form of a contiguous layer applied across backing 66 or
19 in a predetermined broken or contiguous pattern across
20 backing 66.

21

22 In applying backing 66 to flag blank 50, backing 66 is
23 taken up and applied to second face 61 of flag blank 50
24 applying/contacting adhesive 67 to second face 61 of flag

1 blank 50 adhering backing 66 to second face 61 of flag
2 blank 50. In the application of backing 66 to second face
3 61 of flag blank 50, backing 66 is suitably registered
4 relative to second face of flag blank 50 to ensure that in
5 the application of backing 66 to second face 61 of flag
6 blank 50 that backing 66 will cover the entirety of second
7 face 61 of flag blank 50 adhering backing 66 to second face
8 61 of flag blank 50 with adhesive 67. Because adhesive 67
9 is a low-tack adhesive, flag blank 50 and backing 66 can be
10 easily peeled apart from one another and separated leaving
11 second face 61 of flag blank 50 reasonably free of adhesive
12 marking or residue leaving adhesive 67 initially applied to
13 backing 66 maintained on backing 66 and not on second face
14 61 of flag blank 50. Adhesive 67 is a readily available
15 low-tack adhesive.

16

17 As disclosed herein in connection with a preferred
18 embodiment, adhesive 67 is applied between backing 66 and
19 second face 61 of flag blank 50 adhesively adhering backing
20 66 to second face 61 of flag blank 50. In alternate
21 embodiments, backing 66 may be thermally applied or bonded
22 to second face 66 of flag blank 50. For example, a heat-
23 activated composition, which actually functions as an
24 adhesive, may be applied between backing 66 and second face

1 61 of flag blank 50. Heat may then be applied to activate
2 the heat-activated composition and backing 66 forcibly
3 applied onto second face of flag blank 50 to adhesively
4 flag blank 50 to backing 66.

5

6 Instruction sheet 51 is formed of paper or other like
7 or similar substrate suitable for taking on or accepting
8 printing. Referencing FIG. 4B, instruction sheet 51 is
9 substantially the same size and shape as flag blank 50.
10 Like flag blank 50, instruction sheet 51 is rectangular in
11 shape and is broad and thin and flat, and has opposed first
12 and second sides/faces 80 and 81, opposed, parallel inner
13 and outer edges 82 and 83, and opposed, parallel upper and
14 lower edges 84 and 85. Instruction sheet 51 carries
15 instructions for instructing a user how to make a flag with
16 flag-making kit 20 consistent with the flag-making methods
17 set forth in this specification, and provides a test flag
18 template a user may initially use to practice making a flag
19 in preparation for making the real flag with flag blank 50.

20

21 FIG. 8 is an enlarged top plan view of instruction
22 sheet 51 illustrated in FIG. 4B illustrating first face 80
23 of instruction sheet 51 marked with indicia denoted
24 generally at 90. Indicia 90 is sensible indicia that

1 functions to convey information when read or perceived by a
2 user, namely, to convey information functioning to identify
3 first face 80 of instruction sheet 51 as a test flag
4 template. First face 80 of instruction sheet 51 has a
5 broad imprintable area denoted at 91 which is clearly
6 illustrated and which is blank or otherwise free of
7 markings and that is flanked on one side adjacent to and
8 along upper edge 84 of instruction sheet 51 with one
9 component of indicia 90 including printed writing "Test
10 Flag Template" identifying first face 80 of instruction
11 sheet 51 as the test flag template, and is flanked on
12 another side adjacent to and along inner edge 82 of
13 instruction sheet 51 with another component of indicia 90
14 including printed writing consisting of "Support Area", the
15 details of which will be discussed later in this
16 specification.

17

18 FIG. 9 is an enlarged bottom plan view of instruction
19 sheet 51 illustrated in FIG. 4B illustrating second face 81
20 of instruction sheet 51. Second face 81 of instruction
21 sheet 51 is marked with indicia denoted at 92. Indicia 92
22 is sensible indicia that functions to convey information
23 when read or perceived by a user, namely, to convey
24 information functioning to provide instructions for making

1 a flag according to the teachings specified in this
2 specification, in which the instructions relate to steps of
3 design, printing, and assembling a flag as disclosed
4 herein. Indicia 92 consists simply printed writing
5 providing written instructions for making a flag in
6 accordance with the teachings set forth in this
7 specification. Indicia 92 forming the written instructions
8 can take on any form, including simple illustrations,
9 providing a suitable explanation of how to make a flag with
10 flag-making kit 20 consistent with the teachings set forth
11 in this specification.

12

13 Advertisement sheet 52 illustrated in FIG. 4C is, like
14 instruction sheet 51, formed of paper or other like or
15 similar substrate suitable for taking on printing.
16 Referencing FIG. 4B, instruction sheet is substantially the
17 same size and shape as flag blank 50 and instruction sheet
18 51, and is printed with indicia 100. Indicia 100 is
19 sensible indicia that functions to convey information when
20 read or perceived by a user, namely, to convey information
21 functioning as an advertisement communicating product
22 identification of flag-making kit 20 and other selected and
23 relevant advertisement information concerning flag-making
24 kit 20. Indicia 100 can take on any desired form to

1 communicate any desired advertisement about flag-making kit
2 20, including printed wording, illustrations, designs,
3 symbols, pictures, etc. Advertisement sheet 52 is
4 positioned in package 21 to allow it to be seen through
5 packing 21 of flag-making kit 20 by would-be consumers.

6

7 Turning now to FIG. 5, flag support 53 is used to
8 attach a flag to flagpole 22, in accordance with the
9 principle of the invention. Flag support 53 consists of an
10 elongate sleeve 110 having an open upper end 111 and an
11 opposed open lower end 112, and a length extending from
12 open upper end 111 to open lower end 112. Flag support 53
13 also includes a tag 113. Tag 113 is attached exteriorly to
14 sleeve 110, extends away from sleeve 110, and extends along
15 substantially the entire length of sleeve 110 from open
16 upper end 111 to open lower end 112. Tag 113 is elongate.
17 Tag 113 has a generally rectangular shape and has opposed,
18 parallel upper and lower edges 120 and 121, opposed,
19 parallel inner and outer edges 122 and 123, and opposed
20 upper and lower faces 124 and 125. Upper edge 120 is
21 located adjacent to open upper end 111 of sleeve 110, lower
22 edge 121 located adjacent to open lower end 112 of sleeve
23 110, inner edge 122 is affixed exteriorly to sleeve 110 and
24 tag 113 extends outwardly therefrom to outer edge 123. An

1 adhesive 126 is applied to upper face 124 of tag 113.
2 Adhesive 126 is an aggressive, high-tack adhesive, and in
3 this embodiment is formed in a strip extending along
4 substantially the entire length of tag 113 between inner
5 and outer edges 122 and 124 from upper edge 120 to lower
6 edge 121. A backing 127 formed of paper, latex, synthetic
7 elastomer, or other like or similar material or combination
8 of materials, is applied to adhesive 126 covering adhesive,
9 which is peeled away to reveal adhesive 126 in securing a
10 flag according to the principle of the invention.

11

12 Having described the components of flag-making kit 20,
13 preferred methods of making a flag will now be discussed.

14

15

METHOD 1

16 According to an exemplary embodiment of the invention,
17 a method of making a flag according to the principle of the
18 invention includes steps of providing flag blank 50
19 illustrated in FIGS. 4A, 6, and 7, flag blank 50 having
20 opposed first and second faces 60 and 61 illustrated in
21 FIG. 7, adhering backing 66 illustrated in FIG. 7 to second
22 face 61 of flag blank 50, applying flag design indicia 130
23 denoted in FIG. 11 to first face 60 of flag blank 50
24 converting flag blank 50 to a flag 131 in accordance with

1 the principle of the invention, and the reinforcement
2 applied to flag blank 50 in the form of backing 66 applied
3 to second face 61 of flag blank 50 supporting flag blank 50
4 during the step of applying flag design indicia 131 to
5 first face 60 of flag blank 50 converting flag blank 50 to
6 flag 131. Flag design indicia 130 is a desired indicia
7 selected to form the design of flag 131. Flag design
8 indicia 131 may include a pattern of colors, sensible
9 indicia in the form of one or more printed words,
10 abbreviations, one or more illustrations, and/or other
11 selected artwork, designs, and/or wording to form flag
12 design indicia 130, and may represent flag at sea design, a
13 religious design, a linguistic design, a sports or sports
14 team design, a railway design, and political design, a
15 selected personal design, etc. Flag design indicia 130 can
16 be patterned from a predetermined pattern or template, if
17 desired, such as a predetermined pattern or template
18 provided flag making kit 20 or other source.

19

20 As previously explained, backing 66 applied to second
21 face 61 of flag blank 50 is reinforcement to support for
22 flag blank 50 and supports flag blank 50 during the act of
23 applying flag design indicia 131 to first face 60 of flag
24 blank 50 in the process of making a flag according to the

1 principle of the invention. Without reinforcement,
2 applying flag design indicia 130 to first face 60 of flag
3 blank 50 would prove difficult to the pliancy of flag blank
4 50. In a preferred embodiment, flag blank 50 having a
5 pliancy greater than the pliancy of backing 66 allows
6 backing 66 to provide the reinforcement sufficient to
7 support flag blank 50 in the manner herein described. At
8 this point, the method next includes removing the
9 reinforcement, namely, backing 66, from second face 61 of
10 flag 131 as illustrated in FIG. 11, providing flagpole 22
11 illustrated in FIGS. 1, 2, and 3, and mounting flag 131 to
12 flagpole 22 illustrated in FIGS. 12 to form the completed
13 flag illustrated in FIG. 13.

14

15 The step of adhering backing 66 to second face 61 of
16 flag blank 50 in this specific embodiment further includes
17 adhesively adhering backing 66 to second face 61 of flag
18 blank 50, as discussed above, preferably with adhesive 67
19 illustrated in FIG. 7. Furthermore, the step of applying
20 flag design indicia 130 to first face 60 of flag blank 50
21 converting flag blank 50 to flag 131 preferably includes
22 imprinting flag design indicia 130 onto first face 60 of
23 flag blank 50. Imprinting flag design indicia 130 onto
24 first face 60 of flag blank 50 includes, in a preferred

1 embodiment, providing a personal computer 140 operatively
2 coupled to a printer 141 together forming a personal
3 computer workstation 142 as illustrated in FIG. 10,
4 designing flag design indicia 130 with personal computer
5 140, placing flag blank 50 in printer 141, activating
6 printer 141 with personal computer 140 to run flag blank 50
7 through printer 141 imprinting flag design indicia 131 onto
8 first face 60 of flag blank 50, and backing 66 applied to
9 second face 61 of flag blank 50 supporting flag blank 50 as
10 flag blank 50 is run through printer 141 imprinting flag
11 design indicia 130 onto first face 60 of flag blank 50
12 forming flag 131. In other words, flag blank 50 having a
13 pliancy greater than the pliancy of backing 66 applied to
14 second face 61 of flag blank 50 allows backing 66 to
15 support flag blank 50 to allow flag blank 50 to yield and
16 bend when run through printer 141 and allows flag blank 50
17 to be run through printer 141 without flag blank 50
18 bunching up in printer 141 or becoming jammed in printer
19 141.

20

21 Personal computer 140 and printer 141 are entirely
22 conventional. Personal computer 140 includes a central
23 processing unit 150 operative coupled to a personal
24 computer monitor 151, a keyboard 152, if desired a mouse

1 (not shown) or other pointing device, and also to printer
2 141. Printer 141 can be in the form of a laser printer or
3 other conventional printer that takes sheets of material
4 and applies printing to the sheets of material. Personal
5 computer 140 is programmed with any conventional and
6 readily-available software allowing a user to design
7 images, symbols, colors, words and the like into a selected
8 flag design thereby allowing personal computer 140 to be
9 used in the step of designing flag design indicia 130 with
10 personal computer 140. After flag design indicia 130 is
11 created, flag blank 50 is placed in printer 141 and
12 personal computer 140 is used to activate printer 141 to
13 run flag blank 50 through printer 141 imprinting flag
14 design indicia 131 onto first face 60 of flag blank 50. If
15 color forms part of flag design indicia 131, printer 141 is
16 provided as a color printer.

17

18 Before running flag blank 50 through printer 141,
19 advertisement sheet 52 may be taken up, placed in printer
20 141, and run through printer 141 to print flag design
21 indicia 130 onto area 91 of the test flag template of
22 instruction sheet 52 illustrated in FIGS. 4B and 8.
23 Because instruction sheet 52 is substantially the same size
24 and shape as flag blank 50, initially printing flag design

1 indicia 130 onto area 91 of first face 80 of instruction
2 sheet 52 allows a user to check the printing of flag design
3 indicia 130 for accuracy in content, and also position in
4 area 91 of first face 80 of instruction sheet 52, which
5 mimics the printing area onto which flag design indicia 130
6 is to be printed on first face 60 of flag blank 50. The
7 part of indicia 90 applied to first face 80 of instruction
8 sheet denoting "Support Area" relates to the area of flag
9 blank 50 to which flag blank 50 is attached to flag support
10 53 illustrated in FIG. 5, and is provided for reference
11 purposes.

12

13 Removing backing 66 from second face 61 of flag 131
14 after flag 131 is so formed includes peeling backing 66
15 away from second face 61 of flag 131 as illustrated in FIG.
16 11. Because adhesive 67 is a low-tack adhesive as
17 previously explained in the preferred embodiment disclosed
18 therein, second face 61 of flag 131 is substantially free
19 of adhesive markings and residue, in accordance with the
20 principle of the invention.

21

22 Mounting flag 131 to flagpole 22 toward the completion
23 of the method is carried out with the use of flag support
24 53. Flag support 53 is coupled between flagpole 22 and

1 flag 131 to attached or otherwise secure flag 131 to
2 flagpole 22. Referencing FIG. 12, to mount flag support 53
3 to flag pole 22 in this specific embodiment, flagpole 22
4 and flag support 53 are simply taken up, lower end 32 of
5 flagpole 32 is directed into open upper end 111 of sleeve
6 110, and sleeve 110 is run up flagpole 22 to upper end 31
7 locating open upper end 111 of sleeve 110 of flag support
8 43 at upper end 31 adjacent to decorative tip 33. Sleeve
9 110 has an inner diameter only slightly greater than the
10 outer diameter of flagpole 22, in which sleeve 110
11 encircles and frictionally engages or embraces flagpole 22
12 to attached flag support 53 to flagpole 22. If desired,
13 adhesive is applied between sleeve 110 and flagpole 22 to
14 secure flag support 53 in place to flagpole 22.
15 Alternatively, one or more staples, tacks, clips, pins, or
16 other fastener form can be used to secure sleeve 110 to
17 flagpole 22.

18

19 Flag 131 is attached to flag support 53. In the
20 present embodiment, attaching flag 131 to flag support 53
21 involves adhering flag 131 to flag support 53. Adhering
22 flag 131 to flag support 53 includes adhesively adhering
23 flag support 53 to flag 131. To do so with continuing
24 reference to FIG. 12, backing 127 is removed from adhesive

1 126 by taking up backing 127 and peeling it away to reveal
2 adhesive 126. Flag 131 is then taken up and applied to
3 adhesive 126 to adhesively secure flag 131 to tag 113 of
4 flag support 53 to complete the formation of flag as
5 illustrated in FIG. 14. In the present embodiment, an area
6 or region of second face 61 of flag 131 extending along the
7 width of flag 131 from upper edge 64 to lower edge 56 at
8 inner edge 62 is applied to adhesive 126 along the length
9 of tag 113 from upper edge 120 to lower edge 121 in the
10 preferred process of adhering flag 131 to flag support 53
11 to complete the formation of the flag, in which flag 131
12 extends outwardly from inner edge 62 secured to tag 113 of
13 flag support 53 to outer edge 63 as clearly illustrated in
14 FIG. 13. It is to be noted that the width of flag 131
15 along inner edge 62 from upper edge 64 to lower edge 65 is
16 substantially the same as the length of tag 113 from upper
17 edge 120 to lower edge 121 giving the completed flag a
18 clean, integrated appearance. FIG. 14 is a sectional view
19 taken along line 14-14 of FIG. 13 illustrating flagpole 22
20 positioned in sleeve 110 of flag support 53, sleeve 110
21 encircling flagpole 22, adhesive 126 applied to upper face
22 124 of tag 113 adhesively securing an area or region of
23 second face 61 of flag 131 that extends along the width of
24 flag 131 from its upper edge 64 to its lower edge 56 at its

1 inner edge 62 as previously explained, and flag 131
2 extending outwardly from tag 113 and flag support 53.

3

4 Although adhesive 126 is applied to upper face 124 of
5 tag 113, it may be applied to lower face 125 of tag 113,
6 with flag 131 secured in the same manner as previously
7 described. Although the area or region of second face 61
8 of flag 131 that extends along the width of flag 131 from
9 its upper edge 64 to its lower edge 56 at its inner edge 62
10 is applied to adhesive 126, the area or region of first
11 face 61 of flag 131 that extends along the width of flag
12 131 from its upper edge 64 to its lower edge 56 at its
13 inner edge 62 may be applied to adhesive, if desired.
14 Moreover, although adhesive 126 is applied to tag 113,
15 adhesive 126 may, in an alternate embodiment, be applied to
16 first face 60 of flag blank along inner edge 62 or outer
17 edge 63 as may be desired defining a region that, for
18 instance, corresponds to the part of indicia 90 applied to
19 first face of instruction sheet denoting "Support Area".
20 As such, in initially printing flag design indicia 130 onto
21 area 91 of instruction sheet 52, it would be important to
22 ensure the printed flag design indicia 130 would not
23 encounter "Support Area" of first face 80 of instruction

1 sheet 52 to ensure accurate printing of flag design indicia
2 131 onto first face 60 of flag blank 50.

3

4 In carrying out METHOD 1, a user may consult the
5 instructions of how to make a flag according to indicia 92
6 on second face 81 of instruction sheet 51 to aid the user
7 forming a flag according to the method specified in METHOD
8 1. In this embodiment, flag support 53 together with flag
9 131 extends along approximately one-third of the overall
10 length of flagpole 22, and this can be varied as may be
11 desired depending on the length chosen for flagpole 22, the
12 length of flag support 53 and the width of flag 131.

13

14

METHOD 2

15 A method of making a flag according to the principle
16 of the invention includes providing flag-making kit 20
17 illustrated in FIGS. 1-3, including flag blank 50 having
18 opposed first and second faces 60 and 61 and backing 66
19 adhered to second face 61 of backing 66, flagpole 22, flag
20 support 53 adapted to secure a flag to flagpole 22, and
21 package 21, whereby flag blank 50, flag support 53 are
22 enclosed in package 21 and package 21 is attached to
23 flagpole 22 and together have the appearance of a flag
24 raised by flagpole 22 as clearly illustrated in FIGS. 1 and

1 2. The method next specifies detaching package 21 from
2 flagpole 22, and removing flag blank 50 and flag support 53
3 from package 21 as generally illustrated in FIG. 3. The
4 remaining steps of METHOD 2 are that of METHOD 1 as
5 explained in detail above, which include applying flag
6 design indicia 131 to first face 60 of flag blank 50
7 converting flag blank 50 to flag 131, the backing 131
8 applied to second face 61 of flag blank 50 supporting flag
9 blank 50 during the step of applying flag design indicia
10 130 to first face 60 of flag blank 50 converting flag blank
11 50 to flag 131, removing backing 66 from second face 61 of
12 flag 131, and attaching flag 131 flagpole 22 with flag
13 support 53 to complete the formation of the flag as
14 illustrated in FIG. 13.

15

16 In carrying out METHOD 2, instruction sheet 52 may be
17 provided in package 21 and removed from package 21 along
18 with flag blank 50 and flag support 52. A user may consult
19 the instructions of how to make a flag according to indicia
20 92 on second face 81 of instruction sheet 51 to aid the
21 user in forming a flag according to the method specified in
22 METHOD 1. In carrying out METHOD 2, a user may also
23 initially print flag design indicia 130 onto area 91 of

1 first face 80 of instruction sheet 52 as explained in
2 METHOD 1.

3

4

METHOD 3

5 Yet another method of making a flag according to the
6 principle of the invention includes a specific sequence of
7 steps including providing flag blank 50 having opposed
8 first and second faces 60 and 61 and backing 66 adhered to
9 the second face of the flag blank as illustrated in FIG. 7,
10 providing personal computer 140 operatively coupled to
11 printer 141 illustrated in FIG. 10, designing flag design
12 indicia 130 with personal computer 140, placing flag blank
13 50 in printer 141, activating printer 141 with personal
14 computer 140 to run flag blank 50 through printer 141
15 imprinting flag design indicia 130 onto first face 60 of
16 flag blank 50 to form flag 131 illustrated in FIG. 11,
17 backing applied 66 to second face 61 of flag blank 50
18 supporting flag blank 50 as flag blank 50 is run through
19 printer 141 imprinting flag design indicia 130 onto first
20 face 60 of flag blank 50, removing backing 66 from second
21 face 61 of flag 131, providing flagpole 22, and mounting
22 flag 131 to flagpole 22 to form the completed flag
23 illustrated in FIG. 13. The various specific aspects of
24 METHOD 3 relating to the steps of designing flag design

1 indicia 130 with personal computer 140, placing flag blank
2 50 in printer 141, activating printer 141 with personal
3 computer 140 to run flag blank 50 through printer 141
4 imprinting flag design indicia 130 onto first face 60 of
5 flag blank 50, backing applied 66 to second face 61 of flag
6 blank 50 supporting flag blank 50 as flag blank 50 is run
7 through printer 141 imprinting flag design indicia 130 onto
8 first face 60 of flag blank 50, removing backing 66 from
9 second face 61 of flag 131, providing flagpole 22, and
10 mounting flag 131 to flagpole 22 to form the completed flag
11 illustrated in FIG. 13 as are before as described in
12 connection with METHOD 1. In METHOD 2, the described
13 sequence of steps initially more specific as compared to
14 the steps of METHOD 1 thereby forming an embodiment of the
15 invention.

16

17 In carrying out METHOD 3, instruction sheet 52 may be
18 provided in package 21 and removed from package 21 along
19 with flag blank 50 and flag support 52. A user may consult
20 the instructions of how to make a flag according to indicia
21 92 on second face 81 of instruction sheet 51 to aid the
22 user forming a flag according to the method specified in
23 METHOD 1. In carrying out METHOD 3, a user may also
24 initially print flag design indicia 130 onto area 91 of

1 first face 80 of instruction sheet 52 as explained in
2 METHOD 1.

3

4

METHOD 4

5 Yet another method of making a flag according to the
6 principle of the invention includes a specific sequence of
7 steps including providing flag blank 50 (FIG. 4A) having a
8 pliancy, applying a reinforcement to flag blank 50 to
9 reduce the pliancy of flag blank 50, providing personal
10 computer 140 operatively coupled to printer 141 illustrated
11 in FIG. 10, designing flag design indicia 130 with personal
12 computer 140, placing flag blank 50 in printer 141,
13 activating printer 141 with personal computer 140 to run
14 flag blank 50 through printer 141 imprinting flag design
15 indicia 130 onto flag blank 50 to form flag 131 illustrated
16 in FIG. 11, removing the reinforcement from flag 131,
17 providing flagpole 22 illustrated in FIG. 12, and mounting
18 flag 131 to flagpole 22 to form the completed flag
19 illustrated in FIG. 13. The various specific aspects of
20 METHOD 3 relating to the steps of designing flag design
21 indicia 130 with personal computer 140, placing flag blank
22 50 in printer 141, activating printer 141 with personal
23 computer 140 to run flag blank 50 through printer 141
24 imprinting flag design indicia 130 onto flag blank 50,

1 providing flagpole 22, and mounting flag 131 to flagpole 22
2 to form the completed flag illustrated in FIG. 13 as are
3 before as described in connection with METHOD 1. In METHOD
4 4, the described sequence of steps initially more specific
5 as compared to the steps of METHOD 1 and the other
6 described methods thereby forming an embodiment of the
7 invention.

8

9 In carrying out METHOD 4, instruction sheet 52 may be
10 provided in package 21 and removed from package 21 along
11 with flag blank 50 and flag support 52. A user may consult
12 the instructions of how to make a flag according to indicia
13 92 on second face 81 of instruction sheet 51 to aid the
14 user forming a flag according to the method specified in
15 METHOD 1. In carrying out METHOD 4, a user may also
16 initially print flag design indicia 130 onto area 91 of
17 first face 80 of instruction sheet 52 as explained in
18 METHOD 1.

19

20 An exemplary flag-making kit 20 and associated flag
21 making methods are disclosed, and the invention has been
22 described above with reference to preferred embodiments.
23 However, those skilled in the art will recognize that
24 changes and modifications may be made to the embodiments

1 without departing from the nature and scope of the
2 invention, and that the invention is intended to encompass
3 associated flag-making methods embodied within the scope
4 and context of the various disclosed methods consistent
5 with the teachings of the invention set forth in this
6 disclosure.

7

8 For instance, the shape of flag-making materials 43
9 and package 21 can vary depending on specific design
10 requirements. Moreover, the indicia defining instructions
11 and the indicia defining test flag template can be formed
12 on separate sheets, if desired. Adhesive 126 is used to
13 adhere flag 131 to flag support 53. In other embodiments,
14 other mechanisms may be used to adhere or attached flag 131
15 to flag support 53, such as one or more rivets, pins,
16 clips, a hook-and-loop fastener system, etc. In a further
17 embodiment, flag support 53 may be integrated or otherwise
18 formed with flag blank 50. In yet further embodiments,
19 flag 131 may be secured to flagpole 22 directly without the
20 use of support 53, such as with adhesive, tacks, staples,
21 pins, etc. In a particular embodiment, adhesive with an
22 applied and removable backing can be formed directly on
23 flagpole 22 and used to adhesively secure flag 131 to
24 flagpole 22.

1 In securing flag 131 to flagpole 22, opposed collars,
2 stops, or abutments 160 and 161 may be formed or otherwise
3 installed on flagpole 22 as illustrated in FIG. 15.
4 Abutment 160 is formed over and adjacent to open upper end
5 111 of sleeve 110 of flag support 53 and abutment 161 is
6 formed under and adjacent to open lower end 112 of sleeve
7 110 of flag support 53, which together capture flag support
8 53 therebetween preventing flag support 53 from detaching
9 from flagpole 22. In this embodiment, abutment 160 is
10 formed in decorative tip 33. Abutment 161 encircles
11 flagpole 22 in the present embodiment, and may inserted
12 onto flagpole 22, or assembled onto flagpole 22, and
13 secured with adhesive, one or more pins or nails. If
14 inserted onto flagpole 22, abutment 161 may be formed to
15 encircle and frictionally embrace flagpole 22.

16

17 If desired, workstation 42 illustrated in FIG. 10 may
18 form part of a kiosk. Such a kiosk may be located at a
19 mall or other retail establishment or location to allow
20 users to make flags according to the principle of the
21 invention. In this respect, such a kiosk may sell flag
22 making kits constructed and arranged in accordance with the
23 principle of the invention and sold to customers, in which
24 the customers may then use the workstation at the kiosk for

1 making flags with the flag-making kits in accordance with
2 the principle of the invention. Personnel may be provided
3 to man the kiosk and make flags for customers, according to
4 the principle of the invention. In a situation where flags
5 are made for customers, flag-making kits need not be
6 provided, but rather the materials used to make flags
7 according to this disclosure.

8

9 In other embodiments, applying flag design indicia 130
10 to first face 60 of flag blank 50 converting flag blank 50
11 to flag 131 preferably includes imprinting flag design
12 indicia 130 onto first face 60 of flag blank 50. Other
13 ways of applying flag design indicia 130 to first face 60
14 of flag blank 50 can be used in other embodiments. For
15 instance, flag design indicia 130 can be applied through
16 application of one or more stickers on first face 60 of
17 flag blank 50, by drawing and/or coloring onto first face
18 60 of flag blank 50, by ironing decals or heat-transferring
19 decals or the like onto first face 60 of flag blank 50,
20 etc.

21

22 Various further changes and modifications to the
23 embodiment herein chosen for purposes of illustration will
24 readily occur to those skilled in the art. To the extent

1 that such modifications and variations do not depart from
2 the spirit of the invention, they are intended to be
3 included within the scope thereof.

4

5 Having fully described the invention in such clear and
6 concise terms as to enable those skilled in the art to
7 understand and practice the same, the invention claimed is:

CLAIMS

1. A method of making a flag comprising steps of:

providing a flag blank, the flag blank having opposed first and second faces;

adhering a backing to the second face of the flag blank;

applying flag design indicia to the first face of the flag blank converting the flag blank to a flag;

the backing applied to the second face of the flag blank supporting the flag blank during the step of applying the flag design indicia to the first face of the flag blank converting the flag blank to the flag;

removing the backing from the second face of the flag;

providing a flagpole; and

mounting the flag to the flagpole.

2. A method of making a flag according to claim 1, wherein the step of adhering the backing to the second face of the flag blank further comprises adhesively adhering the backing to the second face of the flag blank.

3. A method of making a flag according to claim 1, wherein the step of applying the flag design indicia to the first face of the flag blank converting the flag blank to a flag further comprises imprinting the flag design indicia onto the first face of the flag blank.

4. A method of making a flag according to claim 3, wherein the step of imprinting the flag design indicia onto the first face of the flag blank further comprises steps of:

providing a personal computer operatively coupled to a printer;

designing the flag design indicia with the personal computer;

placing the flag blank in the printer;

activating the printer with the personal computer to run the flag blank through the printer imprinting the flag design indicia onto the first face of the flag blank; and

the backing applied to the second face of the flag blank supporting the flag blank as the flag blank is run through the printer imprinting the flag design indicia onto the first face of the flag blank.

5. A method of making a flag according to claim 1, wherein the step of removing the backing from the second face of the flag further comprises peeling the backing away from the second face of the flag.

6. A method of making a flag according to claim 1, wherein the step of mounting the flag to the flagpole further comprises steps of:

providing a flag support;

mounting the flag support to the flagpole; and

adhering the flag to the flag support.

7. A method of making a flag according to claim 6, wherein the step of adhering the flag to the flag support further comprises adhesively adhering the flag to the flag support.

8. A method of making a flag comprising steps of:

providing a flag-making kit comprising:

a flag blank having a first pliancy, the flag blank having opposed first and second faces, and a backing, having a second pliancy, adhered to the second face of the backing, the pliancy of the flag blank greater than the pliancy of the backing;

a flagpole;

a flag support adapted to secure a flag to the flagpole;

a package;

the flag blank, and flag support enclosed in the package; and

the package attached to the flagpole having the appearance of a flag raised by the flagpole;

detaching the package from the flagpole;

removing the flag blank and the flag support from the package;

applying flag design indicia to the first face of the flag blank converting the flag blank to a flag;

the first pliancy of the flag blank greater than the second pliancy of the backing applied to the second face of the flag blank supporting the flag blank during the step of applying the flag design indicia to the first face of the flag blank converting the flag blank to the flag;

removing the backing from the second face of the flag;

attaching the flag to the flag support; and

mounting the flag support to the flagpole.

9. A method of making a flag according to claim 8, wherein the step of applying the flag design indicia to the first face of the flag blank converting the flag blank to a flag further comprises imprinting the flag design indicia onto the first face of the flag blank.

10. A method of making a flag according to claim 9, wherein the step of imprinting the flag design indicia onto the first face of the flag blank further comprises steps of:

providing a personal computer operatively coupled to a printer;

designing the flag design indicia with the personal computer;

placing the flag blank in the printer;

activating the printer with the personal computer to run the flag blank through the printer imprinting the flag design indicia onto the first face of the flag blank converting the flag blank to a flag; and

the first pliancy of the flag blank greater than the second pliancy of the backing applied to the second face of the flag blank supporting the flag blank as the flag blank is run through the printer imprinting the flag design indicia onto the first face of the flag blank converting the flag blank to the flag.

11. A method of making a flag according to claim 8, wherein the step of removing the backing from the second face of the flag further comprises peeling the backing away from the second face of the flag.

12. A method of making a flag according to claim 1, wherein the step of attaching the flag to the flag support further comprises adhering the flag to the flag support.

13. A method of making a flag according to claim 12, wherein the step of adhering the flag to the flag support further comprises adhesively adhering the flag to the flag support.

14. A method of making a flag comprising steps of:

providing a flag blank, the flag blank having opposed first and second faces, and a backing adhered to the second face of the flag blank;

providing a personal computer operatively coupled to a printer;

designing flag design indicia with the personal computer;

placing the flag blank in the printer;

activating the printer with the personal computer to run the flag blank through the printer imprinting the flag design indicia onto the first face of the flag blank converting the flag blank to a flag;

the backing applied to the second face of the flag blank supporting the flag blank as the flag blank is run through the printer imprinting the flag design indicia onto the first face of the flag blank converting the flag blank to the flag;

removing the backing from the second face of the flag;

providing a flagpole; and

mounting the flag to the flagpole.

15. A method of making a flag according to claim 14, wherein the step of removing the backing from the second face of the flag further comprises peeling the backing away from the second face of the flag.

16. A method of making a flag according to claim 14, wherein the step of mounting the flag to the flagpole further comprises steps of:

providing a flag support;

attaching the flag to the flag support; and

attaching the flag support to the flagpole.

17. A method of making a flag according to claim 16, wherein the step of attaching the flag to the flag support further comprises adhesively adhering the flag to the flag support.

18. A method of making a flag comprising steps of:

providing a flag blank having a pliancy;

applying reinforcement to the flag blank reducing the pliancy of the flag blank;

providing a personal computer operatively coupled to a printer;

designing flag design indicia with the personal computer;

placing the flag blank in the printer;

activating the printer with the personal computer to run the flag blank through the printer imprinting the flag design indicia onto the flag blank converting the flag blank to a flag;

the reinforcement applied to the flag blank supporting the flag blank during the step of imprinting the flag design indicia onto the flag blank converting the flag blank to a flag;

removing the reinforcement from the flag;

providing a flagpole; and

mounting the flag to the flagpole.

19. A method of making a flag according to claim 18, wherein the step of mounting the flag to the flagpole further comprises steps of:

providing a flag support;

attaching the flag to the flag support; and

attaching the flag support to the flagpole.

20. A method of making a flag according to claim 19, wherein the step of attaching the flag to the flag support further comprises adhesively adhering the flag to the flag support.

1 FLAG-MAKING KIT AND METHODS OF MAKING A FLAG

2

3 ABSTRACT

4

5 A method of making a flag includes providing a flag
6 blank having opposed first and second faces and a backing
7 adhered to the second face of the flag blank, and applying
8 flag design indicia to the first face of the flag blank
9 converting the flag blank to a flag. The backing applied
10 to the second face of the flag blank supports the flag
11 blank during the step of applying the flag design indicia
12 to the first face of the flag blank converting the flag
13 blank to the flag. The method next provides removing the
14 backing from the second face of the flag, providing a
15 flagpole, and mounting the flag to the flagpole.

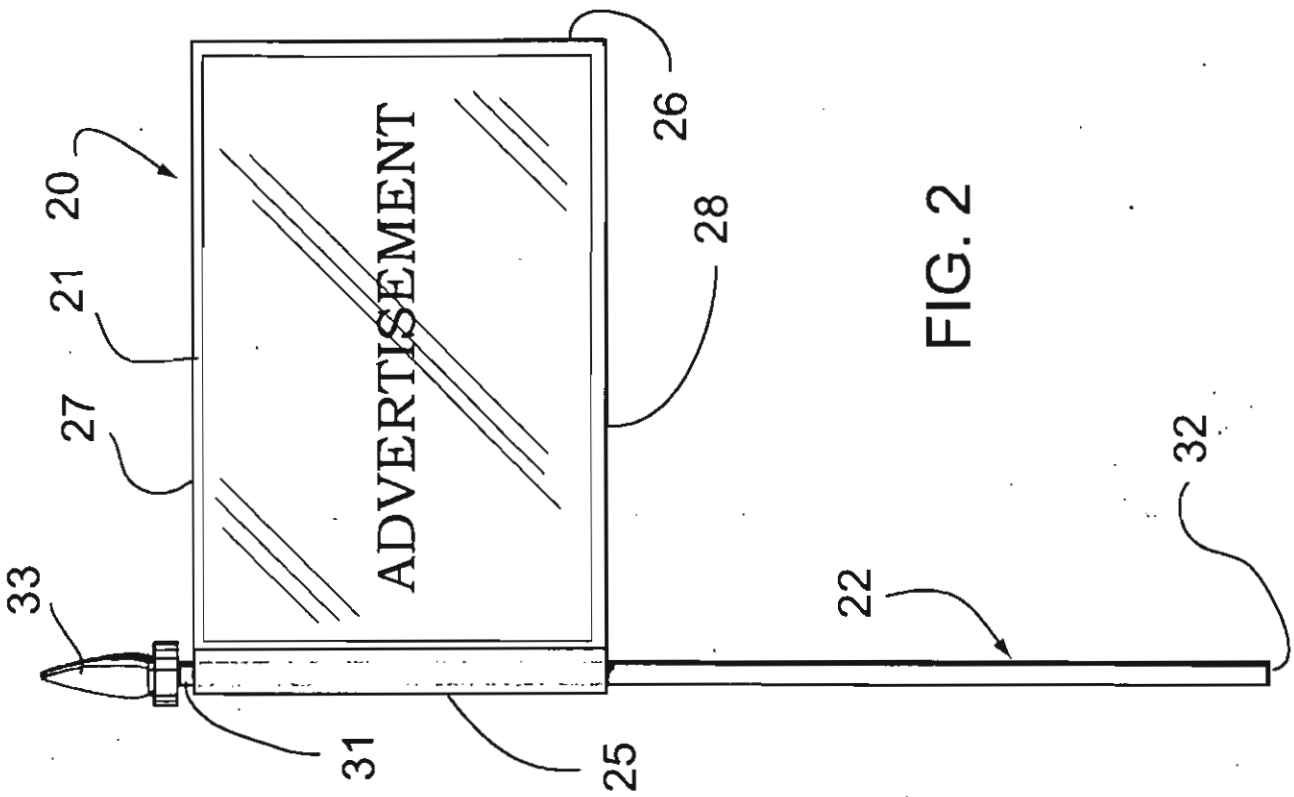

FIG. 2

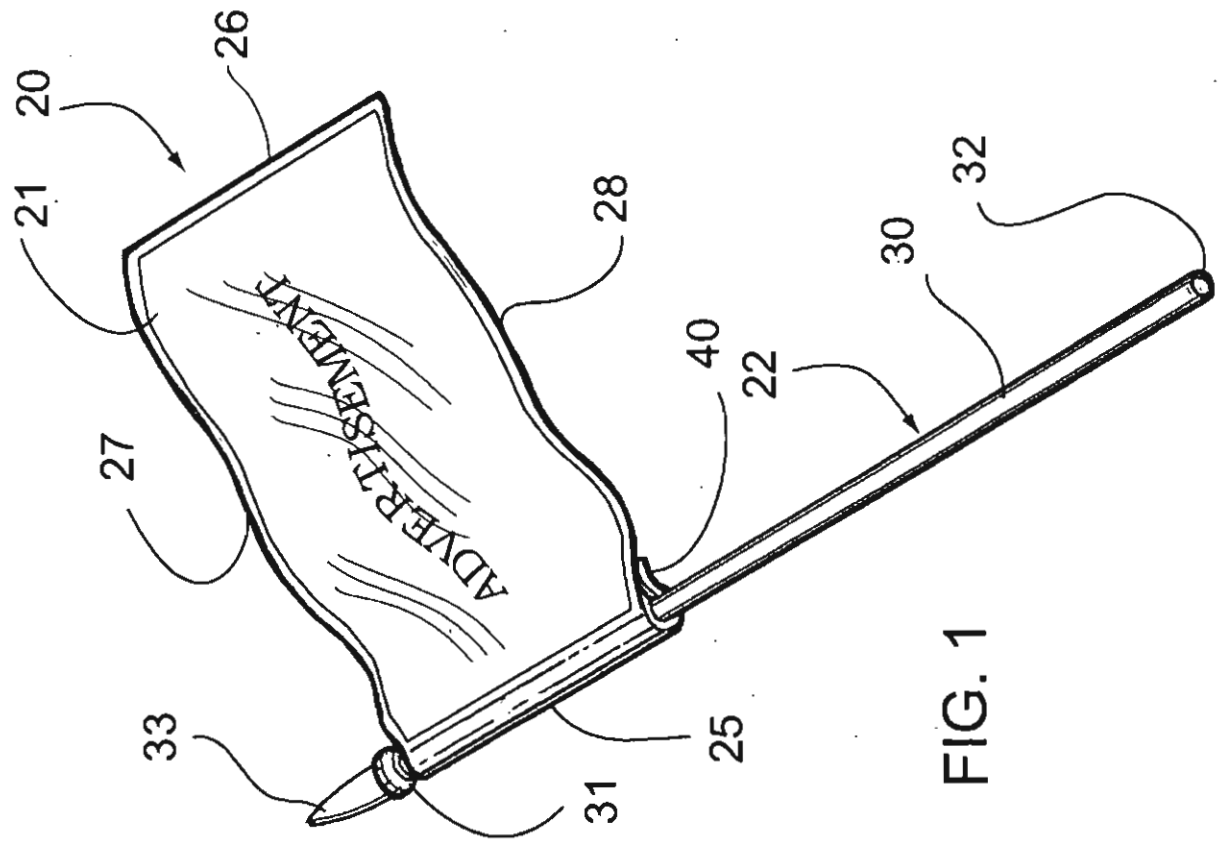
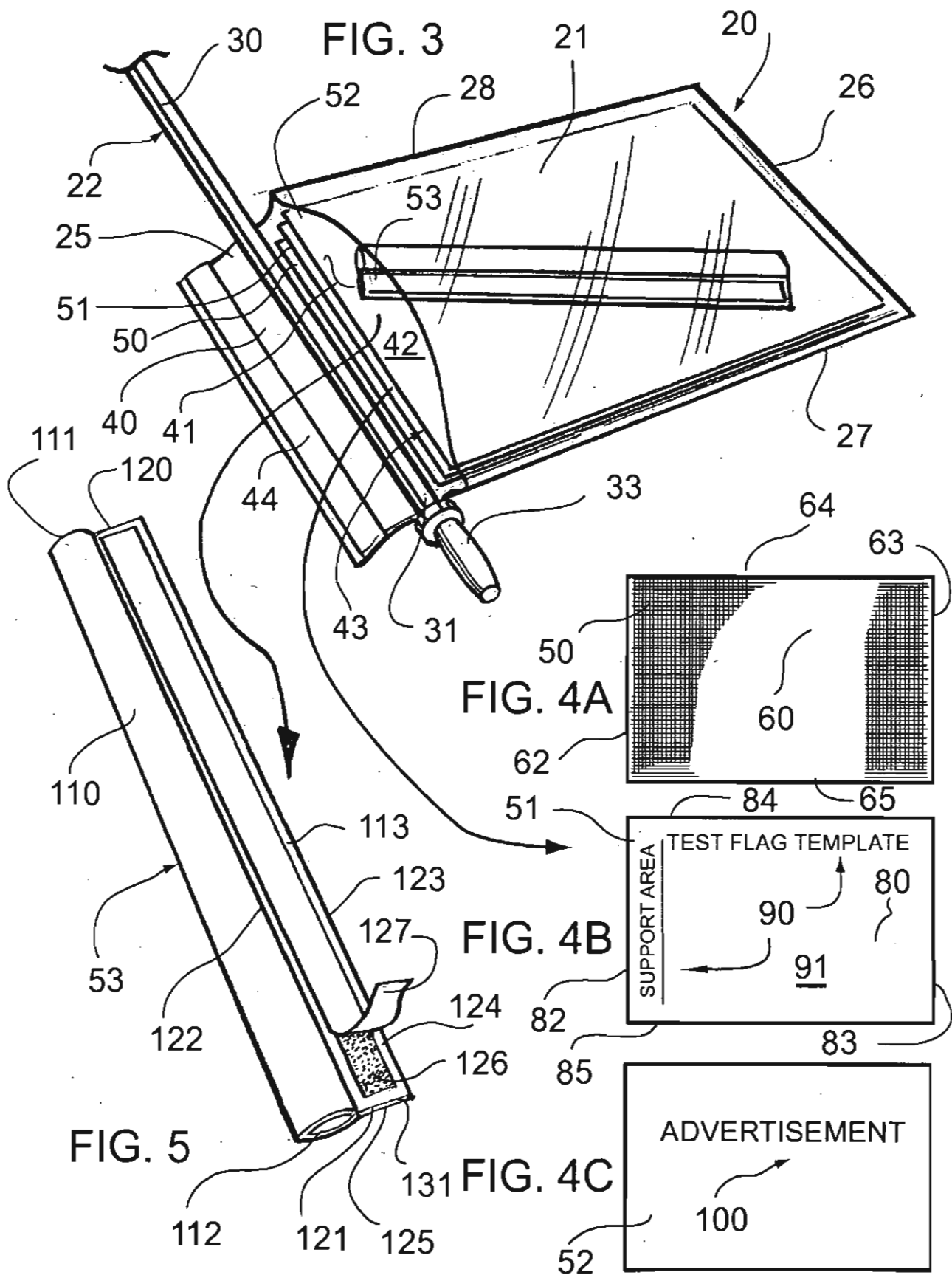

FIG. 1



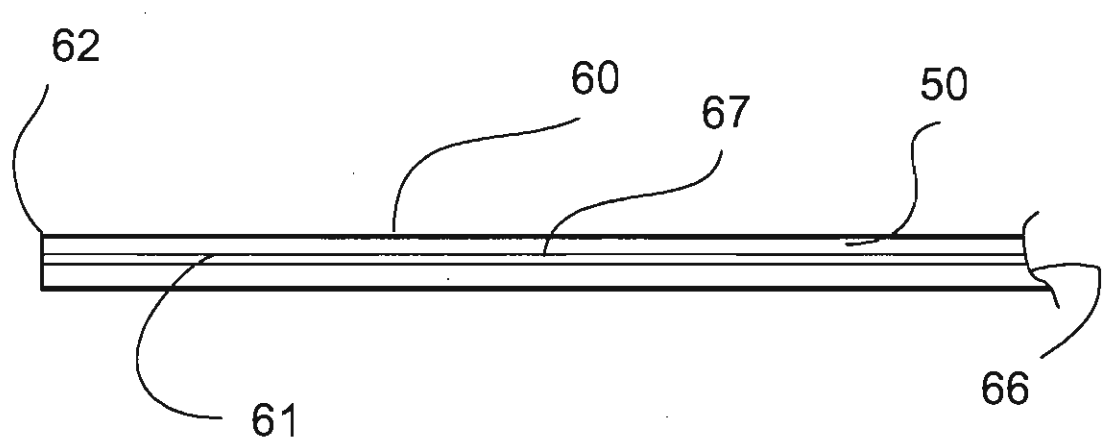
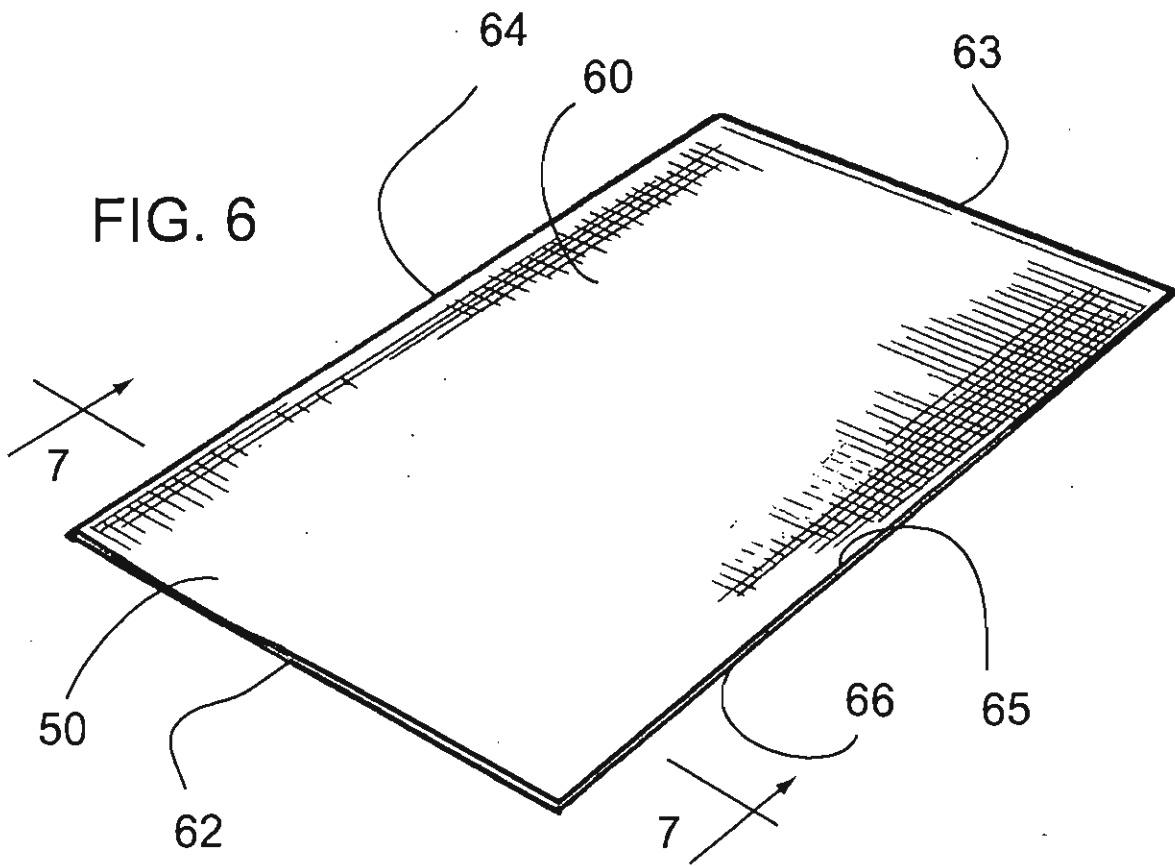

FIG. 7

83 51 84 83

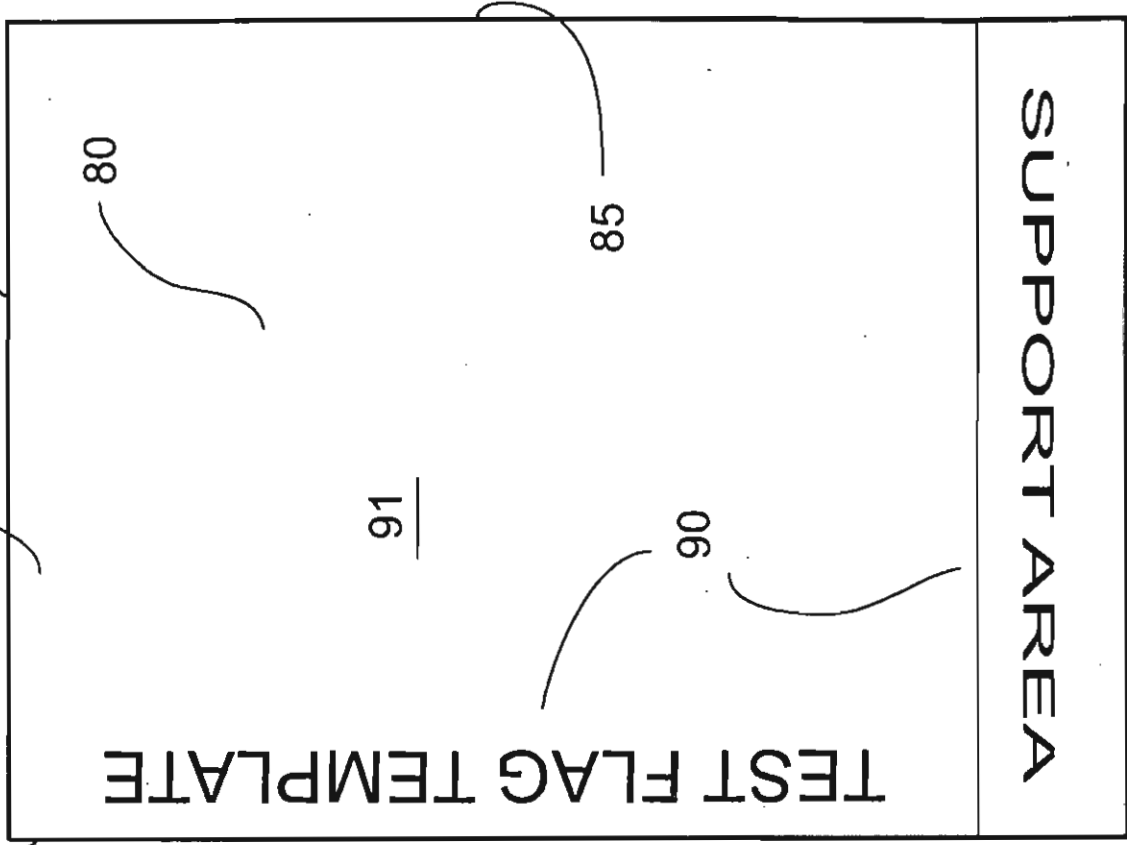

FIG. 8

83 51 84

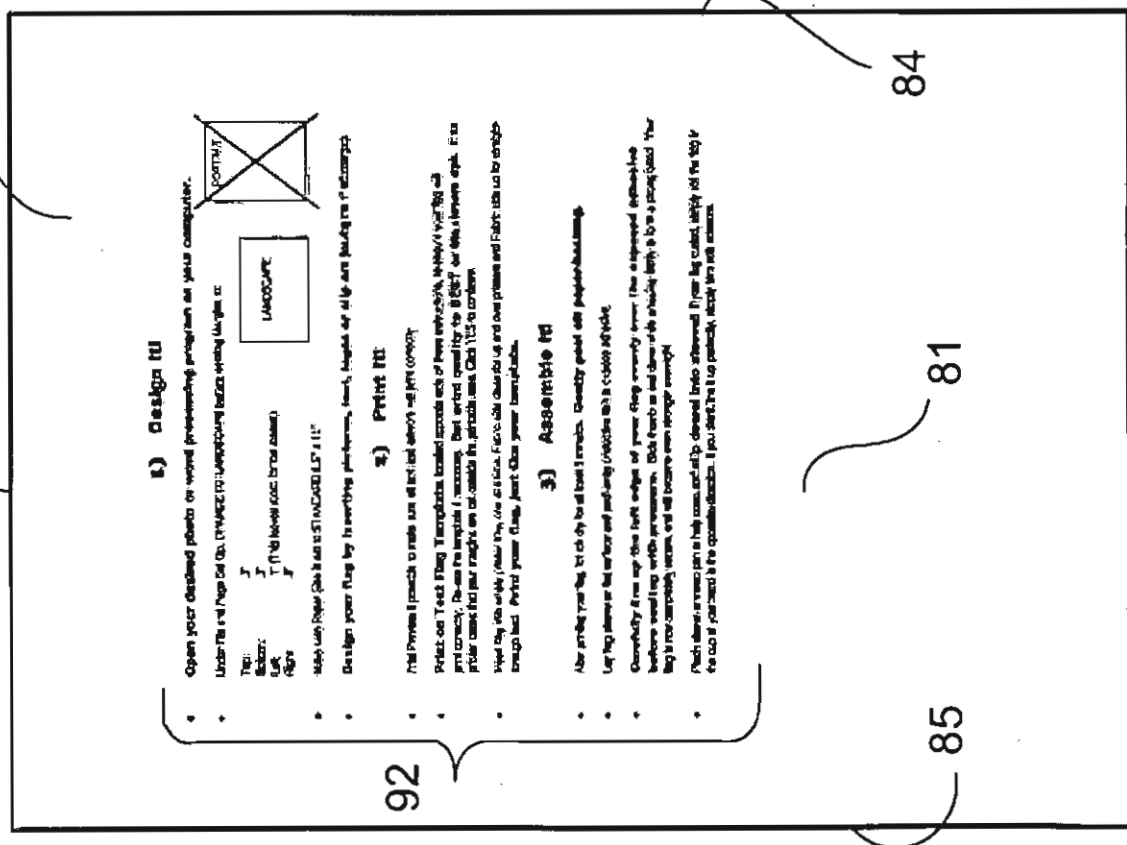

FIG. 9

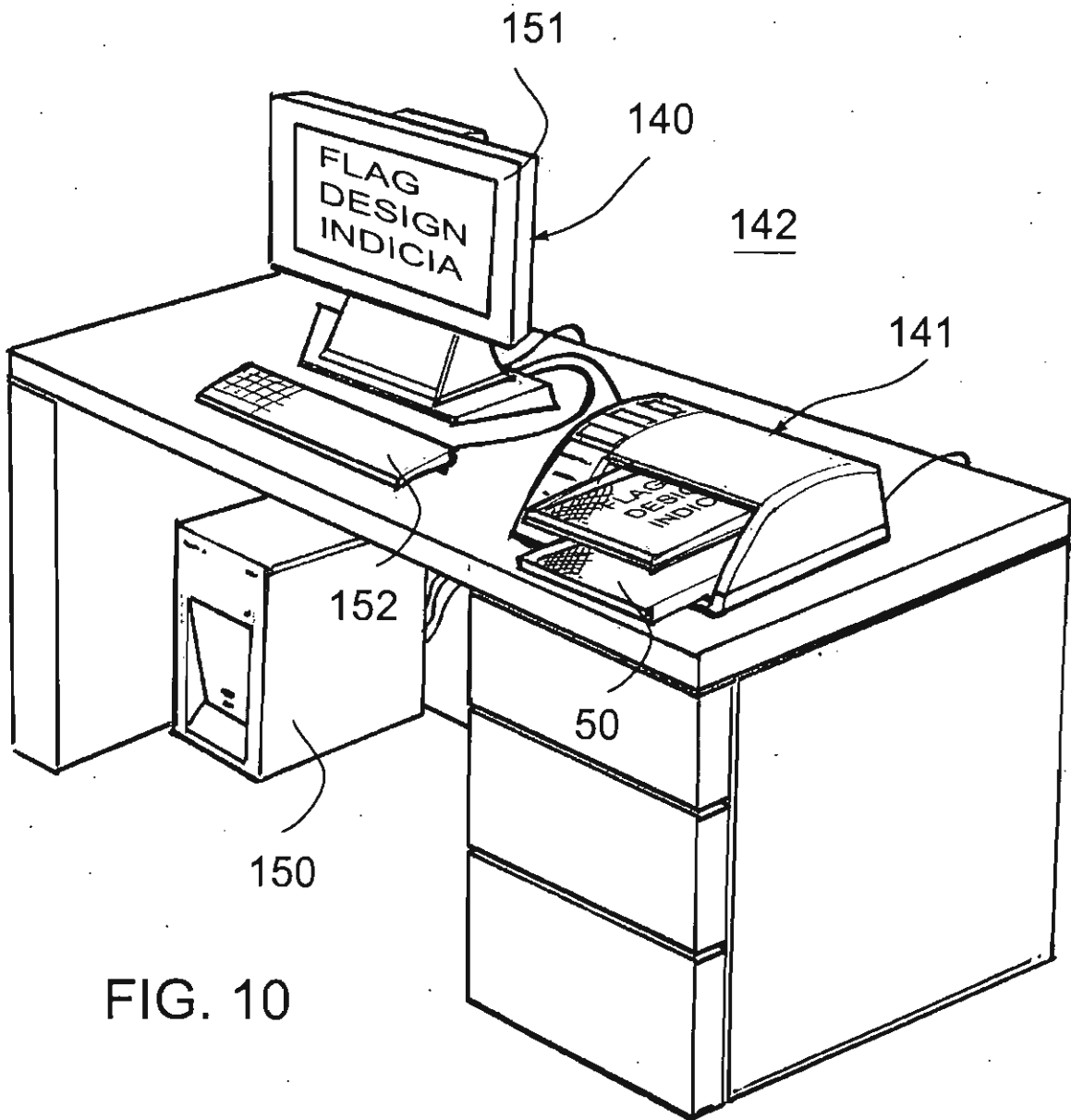

FIG. 10

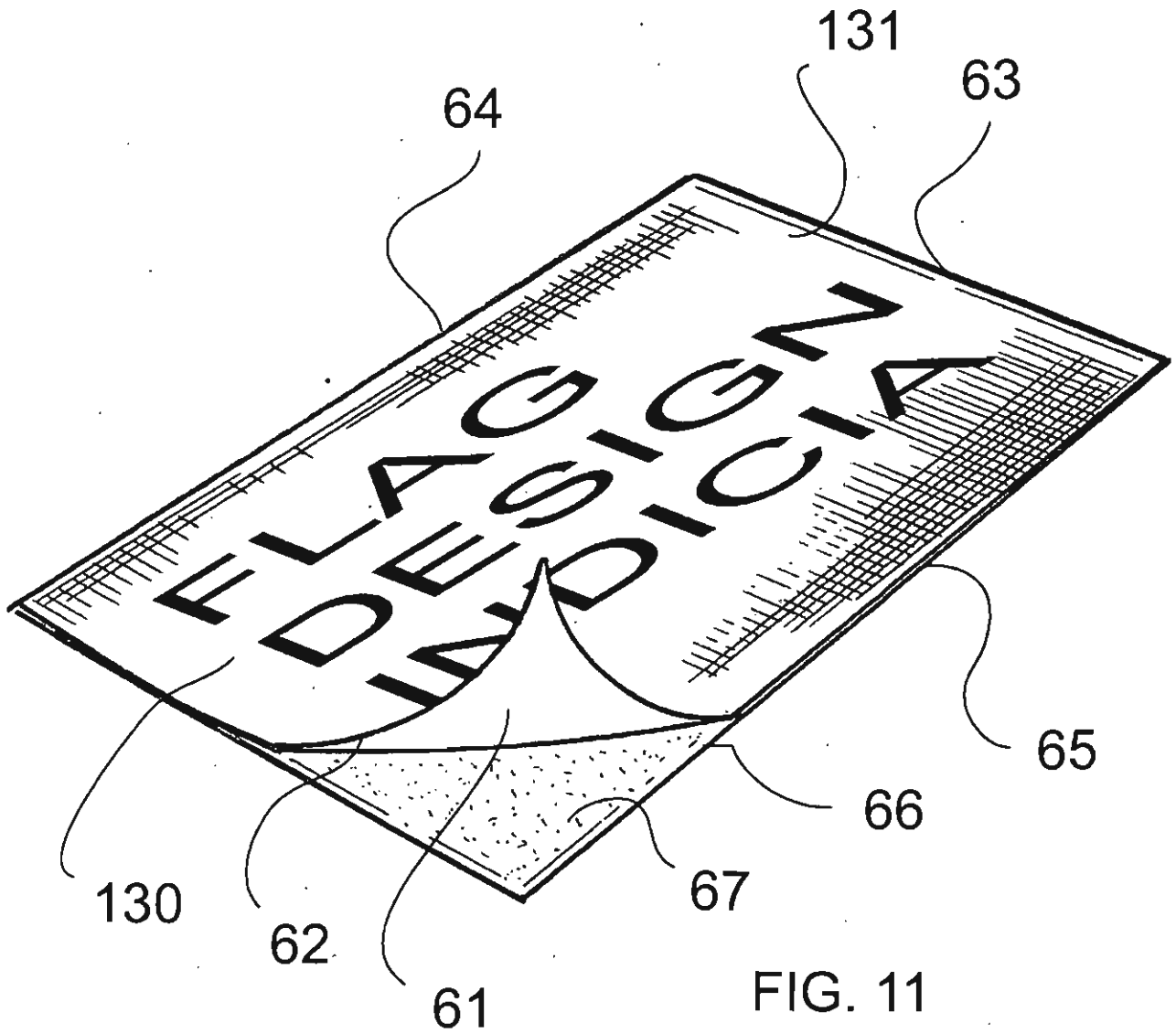

FIG. 11

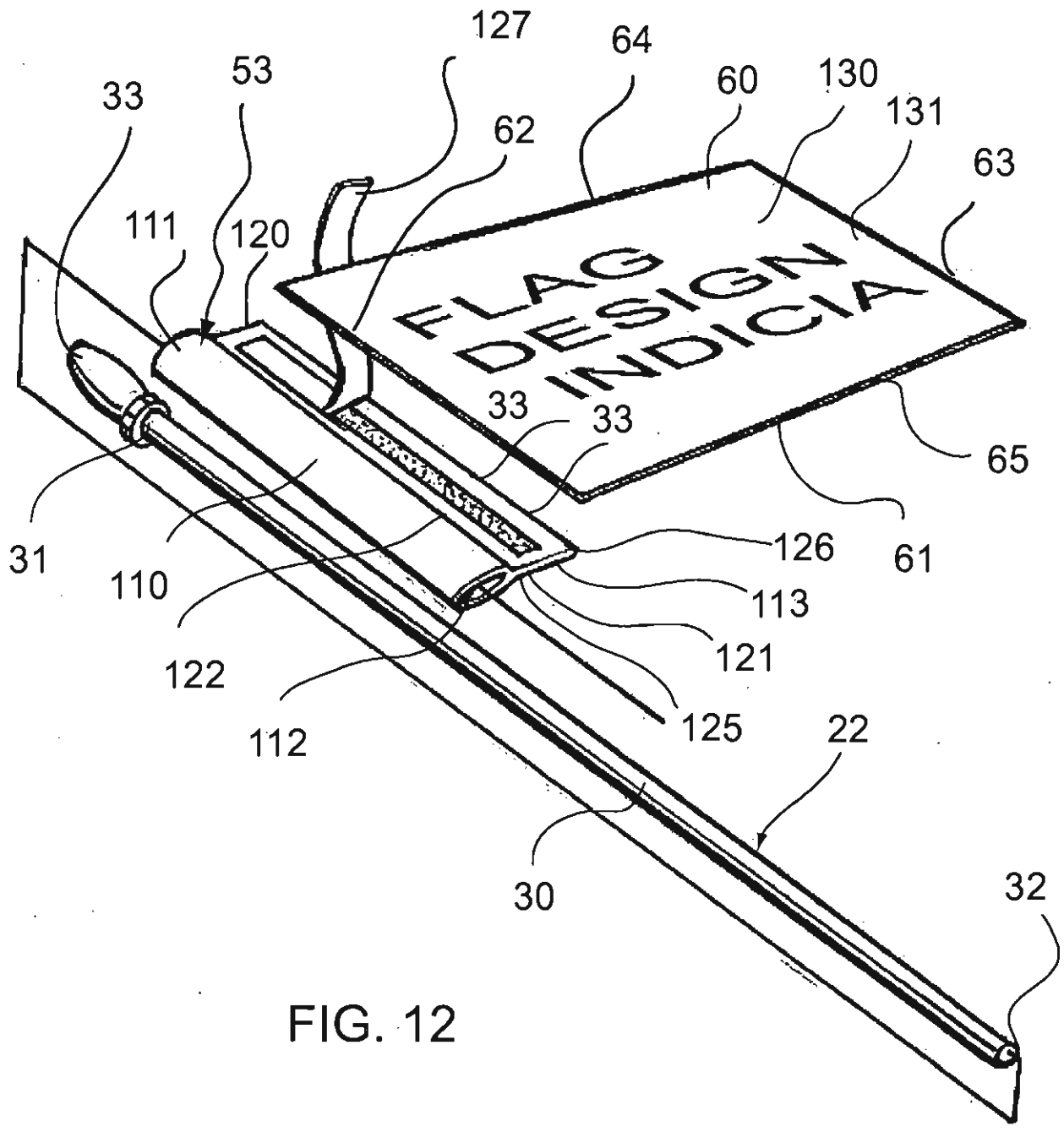

FIG. 12

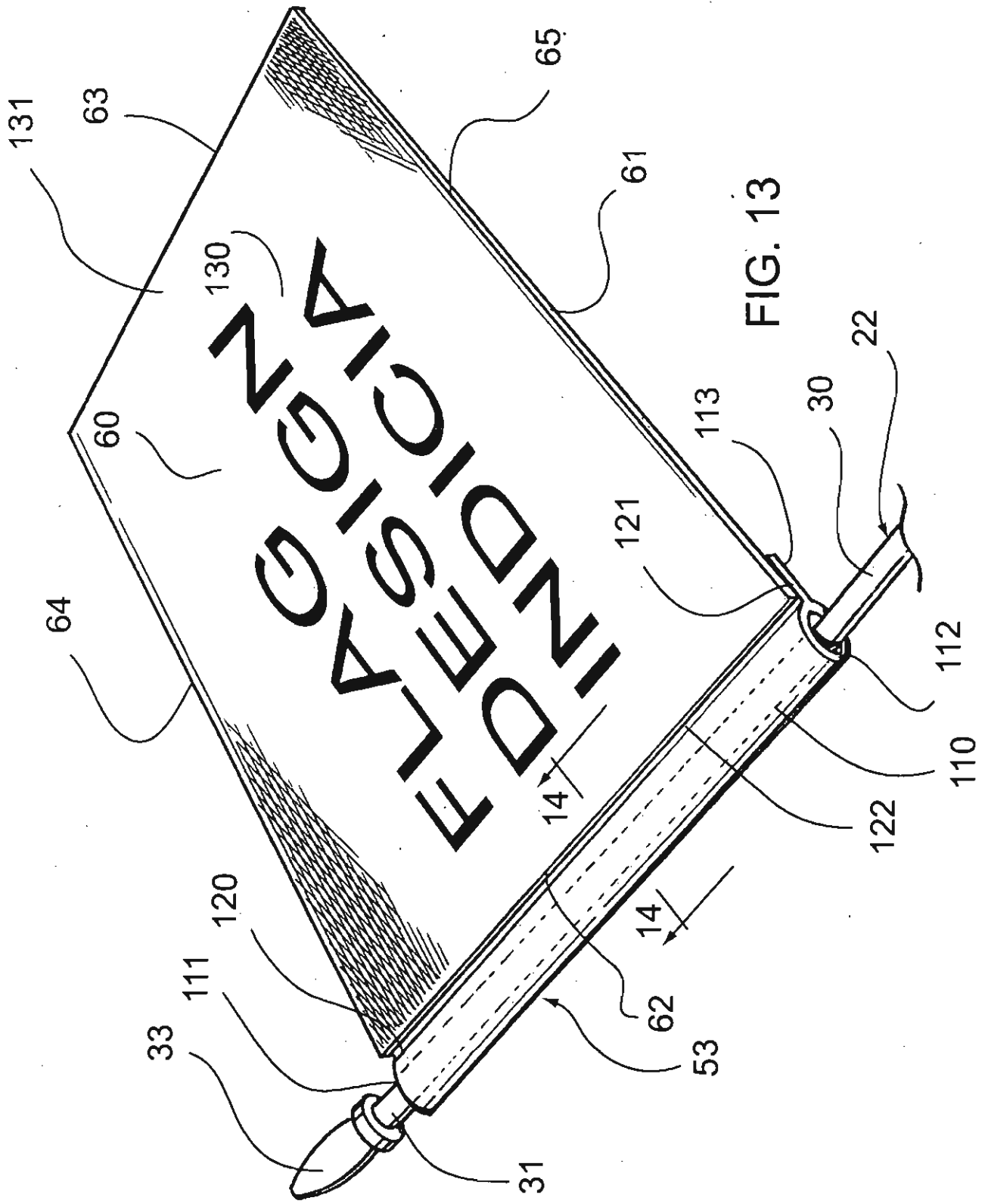
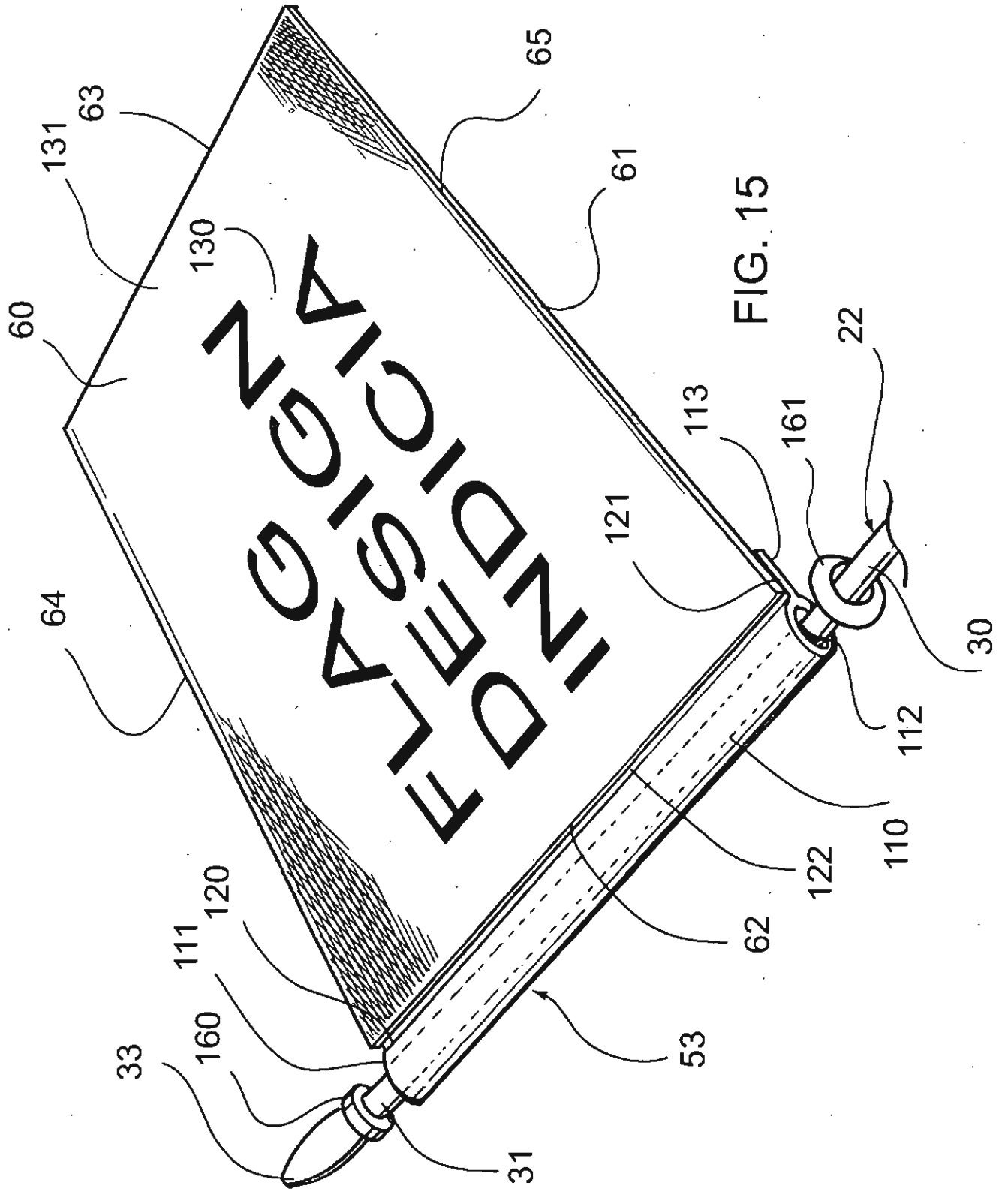

FIG. 13



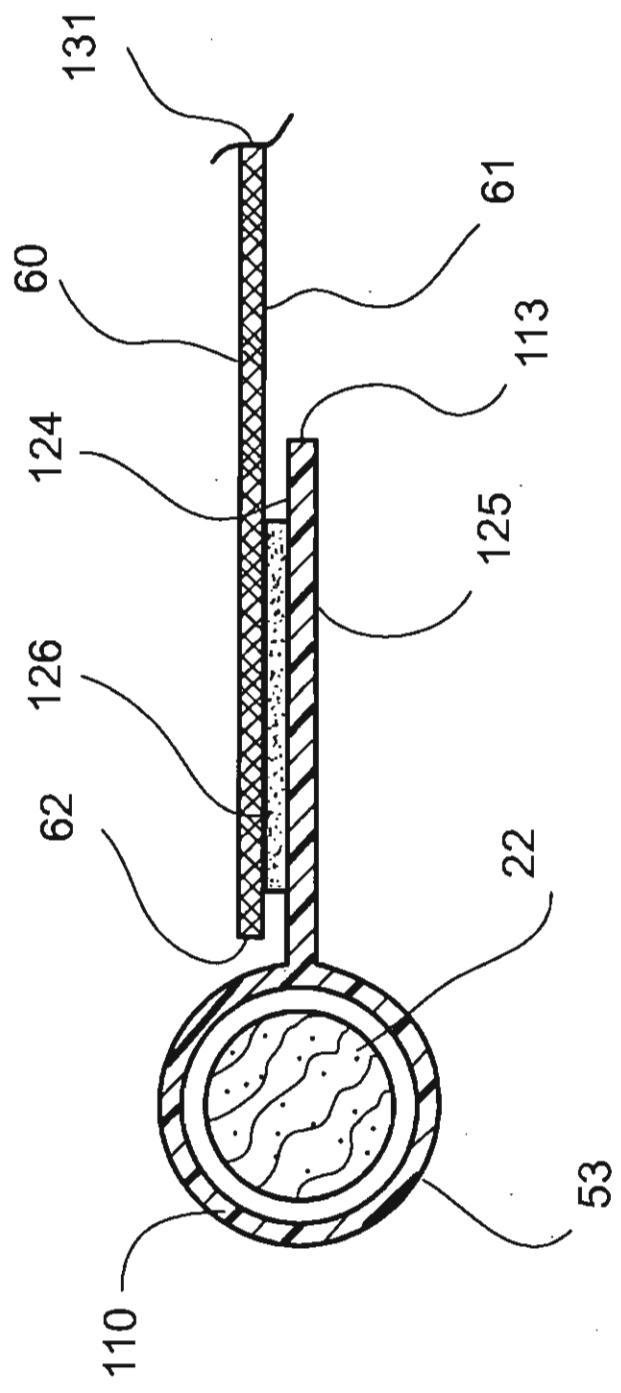

FIG. 14

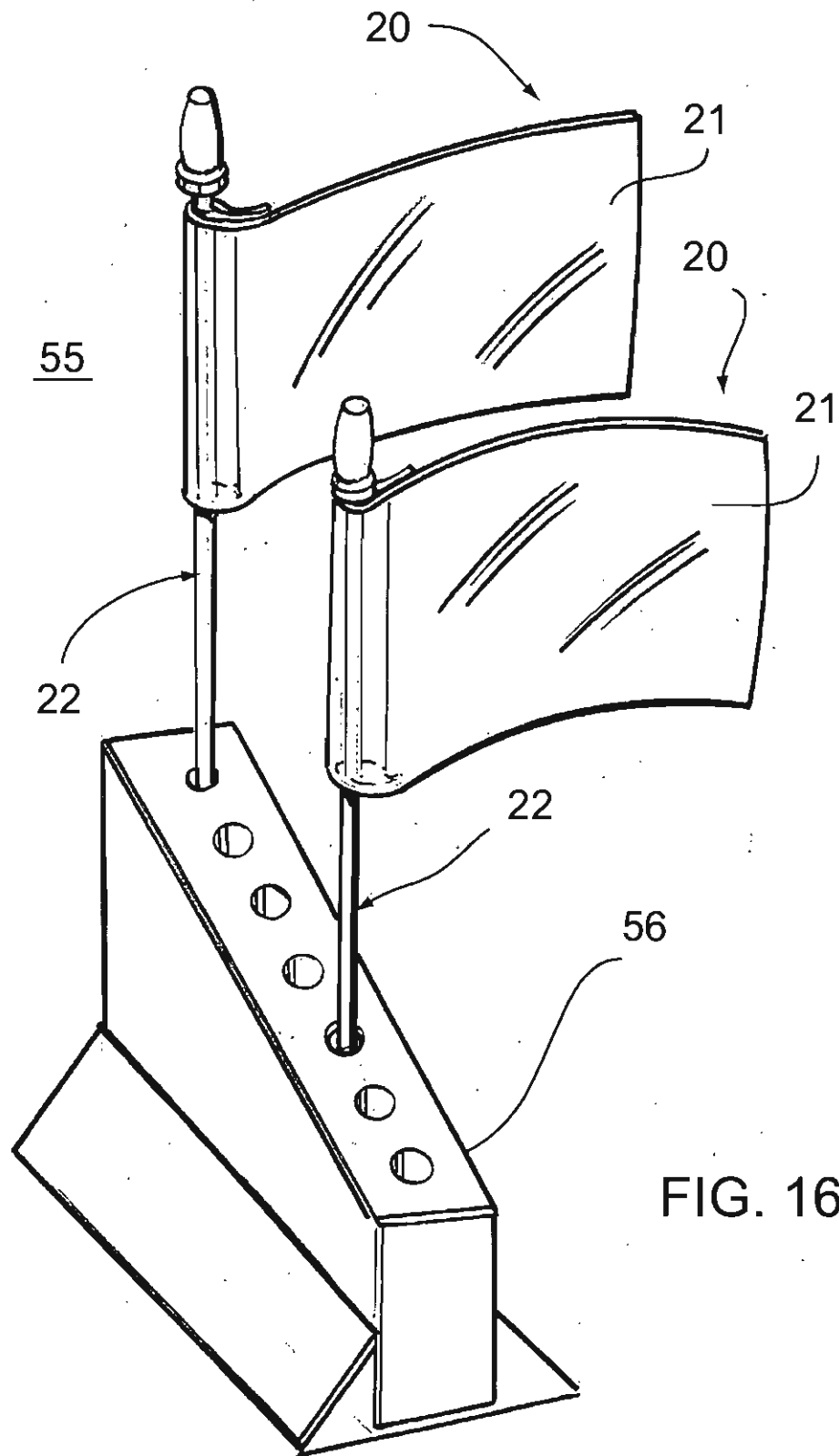

FIG. 16